

Economic Fryer - Fryer

Gas - Donut Fryer

NGDF 8-90



Due to continuous technical development, the image shown may not represent the latest design of the unit.

DESCRIPTION

Free standing gas doughnut fryer with 24 doughnut capacity and 21 kW tubular burners.

Usable for deep frying doughnut, designed for shallow frying.

Manually ignited, includes dedicated cold zone to prolong usable oil lifetime and better fried products. Includes fryer basket, tank cover, crumb filter and oil drain kit.

OTHER AVAILABLE MODELS

- GFE 14 1T
- GFE 14 2T
- GFE 40 RS

MAIN FEATURES

- Powered with four tubular burners, total of 21 kW.
- Can load up to 24 pieces of doughnut in one frying cycle.
- Frying basket, tank cover, oil drain kit, and crumb filter included.
- Fully welded fryer tank.
- Drain valve with 1" on the front surface provided
- Thermal-cut off when overheated.

CONSTRUCTION

- External construction entirely with AISI 430.
- Tank is constructed of 1.5 mm AISI 304.
- Side panel is constructed of 0.8 mm AISI 430.
- Legs with 150 mm height and adjustable position.
- Fryer basket holder made of AISI shaft for ease of claining.
- Well-spaced cavity to prevent accumulated grease from thermal hazard.

INCLUDED ACCESSORIES

- G20 Conversion Kit
- Donut Fryer Basket.
- Crumb filter.
- Oil drain kit.

OPTIONAL ACCESSORIES

- N/A

FRONT

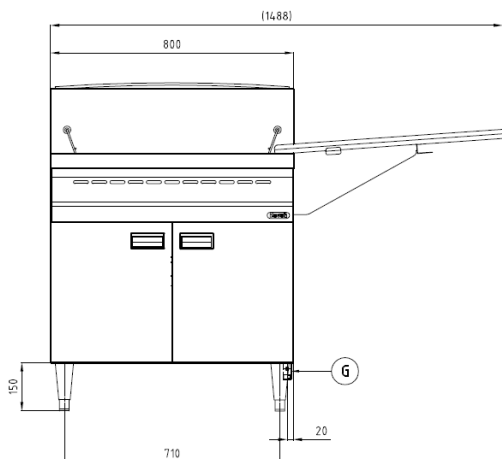

TOP

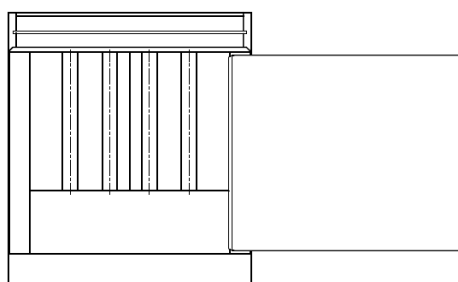

SIDE

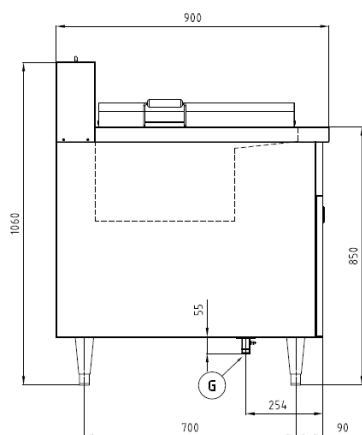

*Overall dimension in mm

TECHNICAL DATA

External Dimensions

Width : 800 mm
Depth : 900 mm
Height : 850/1060 mm

Cooking Surface

Cooking zones : 24 donuts, 660 x 460 mm

Gas Power Rating

Heat input total : LPG/LNG 21 kW
No. of burners : 4
Control type : Modulating temperature control
Gas type options : LPG G30, G31
LNG G20, G25

Connections

Gas : DN 20 (3/4")
Water : N/A
Drain : N/A

Heat & Steam Emissions

Direct heat emission : 1.89 kW
Latent heat emission : 14.70 kW
Steam emission : 21.63 kg/h

PACKAGING DATA

Width : 830 mm
Depth : 930 mm
Height : 1180 mm
Volume : 0.91 m³

WEIGHT

Net Weight : 70 kg
Gross Weight : 82 kg