

## Modular Cooking - Grandis

### Electric - Fry Top

#### NEFT 6-90 C GR



Due to continuous technical development, the image shown may not represent the latest design of the unit.

#### DESCRIPTION

Modular electric fry top with 900 mm depth, powered with 8.5 kW Steady State Surface (SSS) heaters. Equipped with open cabinet.

Usable for contact grilling and starch cooking.

Made of AISI 304 with 2 mm top thickness, griddle is made of 20 mm thick AISI 420, knife steel, that prevent rust and deliver good thermal conductivity. Powered with SSS (Steady-State Surface) that deliver superior temperature distribution and durability.

#### OTHER AVAILABLE MODELS

- NEFT 8-90 GR

#### MAIN FEATURES

- Powered with 8.5 kW SSS heaters.
- Half grooved griddle surface with 450 x 635 mm cooking area.
- Removable flush griddle constructed of AISI 420 with thickness of 20 mm, preventing rust.
- Obround drain with oil collection drawer included.
- Temperature control from 50 degree Celcius to 300 degree Celcius.
- Thermal-cut off when overheated.

#### CONSTRUCTION

- External construction entirely with AISI 304.
- Top panel with 2 mm thickness. Orbital surface finishing: resistant toward scratches.
- Front panel is constructed of 1 mm AISI 304 with satin surface finish.
- Side panel is constructed of 0.8 mm AISI 304 with satin surface finish.
- Adjustable +/- 25 mm AISI leg.
- Cabinet executed with H2 radius.
- Connector between Grandis product on the front and the back.
- IPX4 water protection level.

#### INCLUDED ACCESSORIES

- 1/3 GN food pan for grease waste.

#### OPTIONAL ACCESSORIES

- Joint clip GR.
- Power cable, H07RN-F (5 x 6 mm) p/mtr.
- Swing door 6-90 GR.

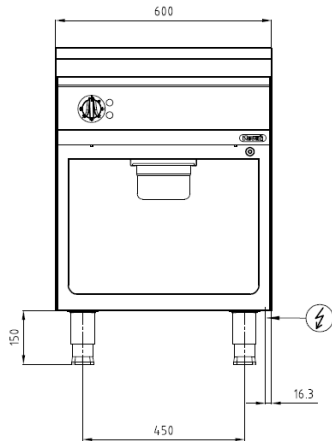
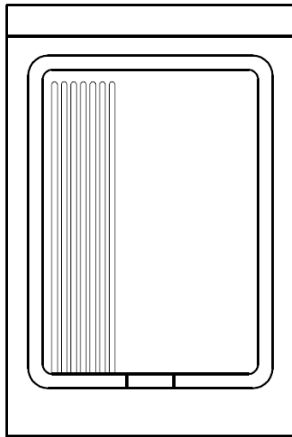
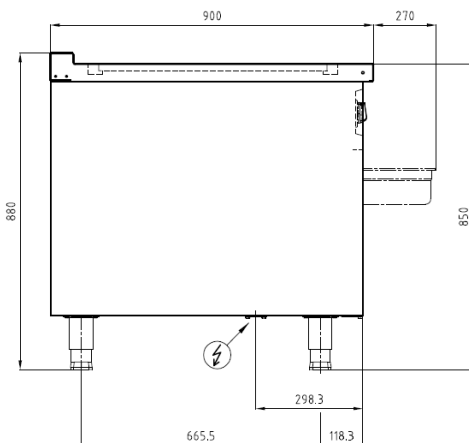
**FRONT****TOP****SIDE**

\*Overall dimension in mm

**TECHNICAL DATA****External Dimensions**

Width	: 600 mm
Depth	: 900 mm
Height	: 850/880 mm

**Cooking Surface**

Cooking zones	: 450 x 670 mm
Heating zones	: 1
Control type	: Modulating temperature control

**Electrical Supply Data**

Total connected load	: 8.5 kW
Voltage	: 400V, 3NPE AC /50-60Hz
Recommended fuse	: 13 A (slow)

**Connections**

Water	: N/A
Drain	: N/A

**Heat & Steam Emissions**

Direct heat emission	: 2.81 kW
Latent heat emission	: 3.4 kW
Steam emission	: 4.50 kg/h

**PACKAGING DATA**

Width	: 630 mm
Depth	: 930 mm
Height	: 1000 mm
Volume	: 0.59 m <sup>3</sup>

**WEIGHT**

Net Weight	: 112 kg
Gross Weight	: 126 kg