

## Oriental Cooking - Gas Steamer

### Gas - Dim Sum Steamer

#### NGSB 9-90 LN



Due to continuous technical development, the image shown may not represent the latest design of the unit.

#### DESCRIPTION

Gas dim sum steamer with one steaming engine for seven dim sum trays steaming capacity. Equipped with high-performance burners of a total of 33 kW power rate for quick steam.

Three steaming operations to achieve the ideal balance between performance and energy-saving when needed. The deck cooling & cleaning system guarantees easy cleaning and a maximum of hygiene.

Powerful and suitable for mass production of dim sum and steamed food, the NGSB steamer is the perfect choice for all Asian restaurants.

#### OTHER AVAILABLE MODELS

- NGSB 9-90 CE
- NGSB 15-90 LN

#### MAIN FEATURES

- High-performance atmospheric burners with a total power rate of 33 kW.
- Electric ignition.
- Equipped with pilot burners, safety thermocouples, gas valves, gas knee levers.
- Slanted, deep drawn, reinforced top panel with drain channel and removable strainer in the front for easy operation.
- Deck cooling & cleaning system with spray nozzles for a maximum hygiene and easy operation.
- Steam box engine with automatic filling system and security thermostat.

#### CONSTRUCTION

- Sturdy frame made of stainless steel AISI 430.
- Slanted, reinforced deep drawn stainless steel top panel (3.2 mm), AISI 304 with hairline surface pattern.
- Front and side panels made of stainless steel AISI 304 with hairline surface pattern (0.8 mm).
- Backsplash made of stainless steel AISI 304 with hairline surface pattern (1.2 mm).
- Tubular, height adjustable ( $\pm 25$  mm) stainless steel legs.
- Types of installations: free standing or placed on a plinth.
- Frame, top and panels, all made of high-grade stainless steel.

#### INCLUDED ACCESSORIES

- Dim sum plate with seven holes.

#### OPTIONAL ACCESSORIES

- Dim sum tray kit - two levels with lid for max. 24 pcs bamboo trays  $\varnothing$  130 mm.

PT. NAYATI INDONESIA

[www.nayati.com](http://www.nayati.com)

Nayati reserves the right to make product alterations and or price adjustments at any time and can not be held responsible for any printing errors or omissions.

**FRONT**

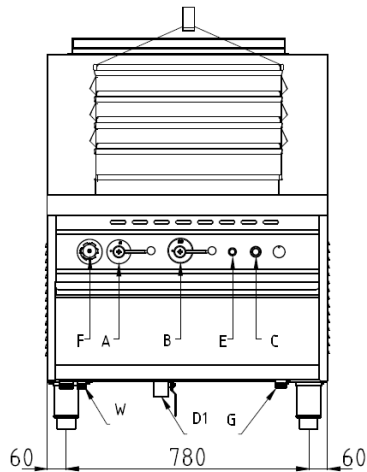

**TOP**

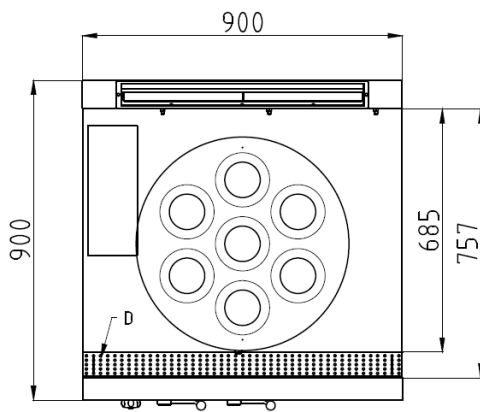

**SIDE**

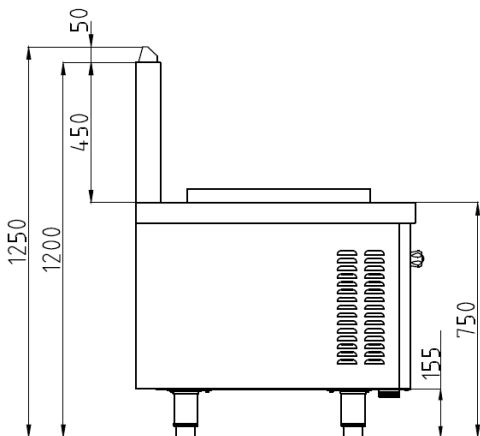

\*Overall dimension in mm

**TECHNICAL DATA**

**External Dimensions**

Width : 900 mm  
 Depth : 900 mm  
 Height : 750/1200 mm

**Cooking Surface**

Cooking zones : Ø 600 mm

**Gas Power Rating**

Heat input total : LPG/LNG 33 kW, and 0.004 kW - 230V, 1NPE AC / 50-60 Hz

No. of burners : 3

Control type : High-low power control

Gas type options : LPG G30  
 LNG G20, G25

**Connections**

Gas : DN25 (1")  
 Water : DN15 (1/2")  
 Drain : DN32 (1 1/4") & DN40 (1 1/2")

**Heat & Steam Emissions**

Direct heat emission : LPG/LNG 4.95 kW  
 Latent heat emission : LPG/LNG 5.94 kW  
 Steam emission : LPG/LNG 8.75 kg/h

**PACKAGING DATA**

Width : 930 mm  
 Depth : 930 mm  
 Height : 1320 mm  
 Volume : 1.14 m<sup>3</sup>

**WEIGHT**

Net Weight : 141 kg  
 Gross Weight : 205 kg