

Asian Cooking - Gas Steamer
Gas -Three Deck Steam Cabinet
NGSCD 9-90 CE



Due to continuous technical development, the image shown may not represent the latest design of the unit.

DESCRIPTION

Gas steam cabinet with three decks. Equipped with high-performance premix burners with a total of 42 kW power rate for quick steam and a low combustion noise of below 70 dBA.

Each steam chamber is individually controlled with three steaming operations to achieve the ideal balance between performance and energy-saving when needed.

Powerful, compact, and suitable for rice and any steamed food, the NGSCD steamer is the perfect choice for high-frequent Asian restaurants.

OTHER AVAILABLE MODELS

- NGSCD 9-90 LN
- NGSCD 12-90 LN

MAIN FEATURES

- High-performance premix burners with blowers and a total power rate of 42 kW. Low combustion noise of <70 dB.
- Electric ignition.
- Equipped with gas valves, gas failure security and gas knob.
- Steam box engine with automatic filling system and security thermostat.
- Three, individually controlled steam chambers. Top & middle deck with 660/615/220 mm, bottom deck 660/615/400 mm (w/d/h) internal dimensions.
- CE certified unit.

CONSTRUCTION

- Sturdy frame made of stainless steel AISI 430.
- Front and side panels made of stainless steel AISI 304 with hairline surface pattern (0.8 mm).
- Back panel made of stainless steel AISI 304 with hairline surface pattern (0.8 mm).
- Tubular, height adjustable (± 10 mm) stainless steel legs.
- Types of installations: free standing or placed on a plinth.
- Unit made of high-grade stainless steel.

INCLUDED ACCESSORIES

- Stainless steel wire grills 650x600 mm (4 pcs).

OPTIONAL ACCESSORIES

- N/A

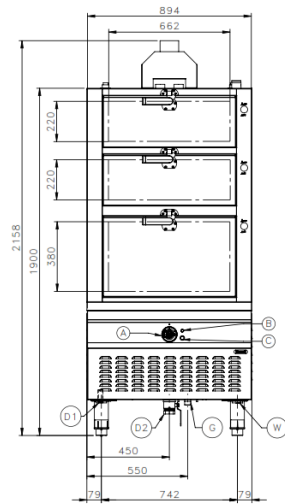
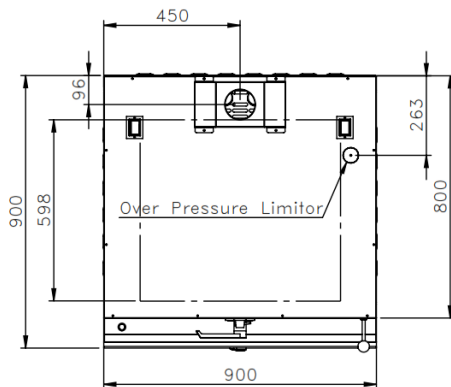
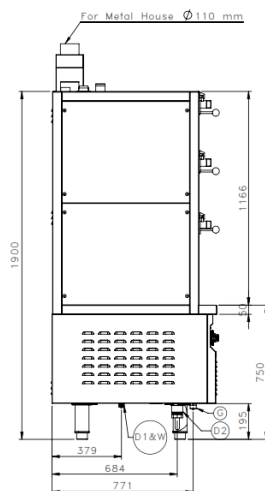
FRONT**TOP****SIDE**

*Overall dimension in mm

TECHNICAL DATA**External Dimensions**

Width	: 900 mm
Depth	: 900 mm
Height	: 750/2158 mm

Cooking Surface

Cooking zones : 650 x 600 (3pcs) mm

Gas Power RatingHeat input total : LPG/Natural Gas 42 kW, and 0.14 kW
- 230V, 1PNE AC / 50-60 Hz

No. of burners : 2

Control type : High-low power control

Gas type options: LPG G30, G31
Natural Gas G20, G25**Electrical Supply Data**

Total connected load	: 0.14 kW
Voltage	: 230V, 1PNE AC / 50-60 Hz
Recommended fuse	: 6 A (slow)

Connections

Gas	: DN25 (1")
Water	: DN20 (3/4")
Drain	: DN20 (3/4") & DN40 (1 1/2")

Heat & Steam Emissions

Direct heat emission	: LPG/Natural Gas 6.30 kW
Latent heat emission	: LPG/Natural Gas 7.56 kW
Steam emission	: LPG/Natural Gas 11.13 kg/h

PACKAGING DATA

Width	: 1000 mm
Depth	: 1020 mm
Height	: 2358 mm
Volume	: 2.41 m ³

WEIGHT

Net Weight	: 235 kg
Gross Weight	: 300 kg