

Modular Cooking - Meritus

Gas - Range

NGTR 8-75 (ME)



Due to continuous technical development, the image shown may not represent the latest design of the unit.

DESCRIPTION

Modular gas open burner with 750 mm depth and 4 hobs, 2 sets of 3.5 kW and 7.5 kW cast iron burners.

Usable for boiling, steaming, frying, braising, simmering and steam frying.

Made of AISI 304 with 1.5 mm top thickness, manual ignited, fully welded basin for hygiene purpose, galvanized coated cast iron burner. Oven is sized for 2/1 GN with reflective AISI cavity for superior heat transfer.

OTHER AVAILABLE MODELS

- NGR 8-75 (ME)
- NGR 12-75 (ME)
- NGTR 4-75 (ME)
- NGTR 12-75 (ME)
- NGR 8-75 EOVS (ME)
- NGR 12-75 EOVS (ME)

MAIN FEATURES

- Powered with a 4 hobs, 2 sets of 3.5 kW and 7.5 kW cast iron open burner.
- Fully-welded basin for hygiene.
- Cast iron pot holder with long fin to support various size of pot or pan.
- Equipped with flame failure device.
- The optimized pan diameter for 3.5 kW burner is between 240-380 mm.
- The optimized pan diameter for 7.5 kW burner is between 300-500 mm.

CONSTRUCTION

- External construction entirely with AISI 304.
- Top panel with 1.5 mm thickness. Orbital surface finishing: resistant toward scratches.
- Front panel is constructed of 0.8 mm AISI 304 with satin surface finish.
- Side panel is constructed of 0.8 mm AISI 304 with satin surface finish.
- Adjustable +/- 25 mm AISI leg.
- Nayati connection system between Meritus products on the front panels, cabinets, and splashbacks.
- Cabinet executed with H2 radius.
- Deep drawn front panel to minimize liquid penetration to the internal part.
- Gasket protection behind the knobs to prevent water to seeping in, prolonging main heating regulation parts.

INCLUDED ACCESSORIES

- G20 Conversion Kit
- Cast iron pot holder.

OPTIONAL ACCESSORIES

- Stainless steel pot holder ME.
- Joint clip ME.
- Swing door 8-75 ME.

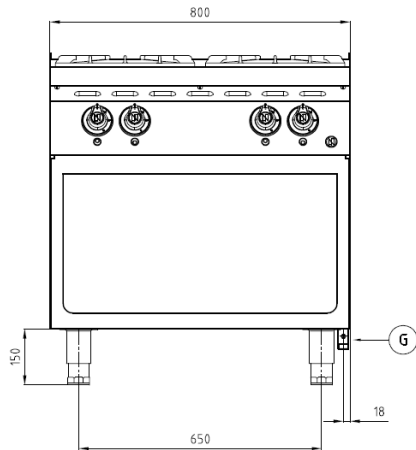
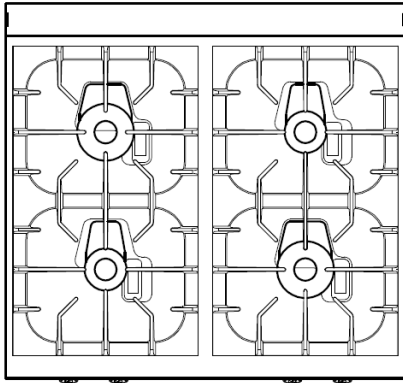
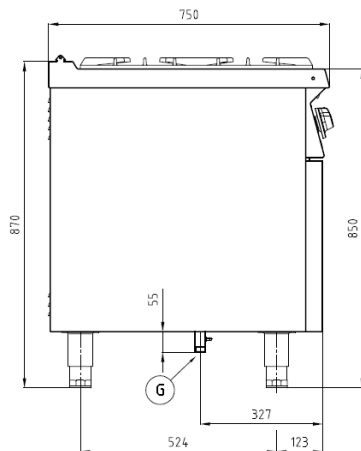
FRONT**TOP****SIDE**

*Overall dimension in mm

TECHNICAL DATA**External Dimensions**

Width	: 800 mm
Depth	: 750 mm
Height	: 850/900 mm

Cooking Surface

Cooking zones	: 2 x 305 x 620 mm
---------------	--------------------

Gas Power Rating

Heat input total	: LPG/Natural Gas 22 kW
No. of burners	: 4
Control type	: High - low power control
Gas type options	: LPG G30, G31 Natural Gas G20, G25

Connections

Gas	: DN 20 (3/4")
Water	: N/A
Drain	: N/A

Heat & Steam Emissions

Direct heat emission	: 5.5 kW
Latent heat emission	: 2.2 kW
Steam emission	: 3.23 kg/h

PACKAGING DATA

Width	: 830 mm
Depth	: 780 mm
Height	: 1020 mm
Volume	: 0.66 m ³

WEIGHT

Net Weight	: 74 kg
Gross Weight	: 92 kg