

Modular Cooking - Amicus

Gas - Wok Ring Table

NGWT 3-55 AM



Due to continuous technical development, the image shown may not represent the latest design of the unit.

DESCRIPTION

Table top gas wok range with 600 mm depth and 11.5 kW (G30) or 13 kW (G20) gas wok burner.

Usable for wok sauteeing, boiling, simmering and shallow frying.

Made of AISI 304 with 1.2 mm top thickness, manual ignited, includes wok-ring adaptor.

OTHER AVAILABLE MODELS

- N/A

MAIN FEATURES

- Powered with 11.5 kW (G30) or 13 kW (G20) cast iron wok burner.
- Deep drawn top for hygienic
- Cast iron pot holder with long fin to support various size of pot or pan.
- Includes wok adaptor for versatility between wok and pan/pot.
- Equipped with flame failure device.

CONSTRUCTION

- External construction entirely with AISI 304.
- Top panel with 1.2 mm thickness. Orbital surface finishing: resistant toward scratches.
- Side panel with 1.2 mm deep-drawn surface.
- Front panel with 0.8 mm deep-drawn surface.
- Top panel with Orbital scratch-preventing finish.
- Rubber leg with 40 mm height
- Connector between Amicus product on the back.

INCLUDED ACCESSORIES

- G20 Conversion Kit
- Amicus joining clip.
- Wok ring adaptor with diameter of 280 mm.
- Waste drawer.

OPTIONAL ACCESSORIES

- N/A

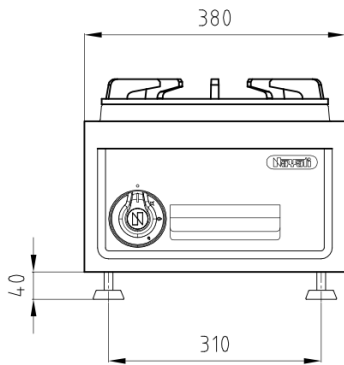
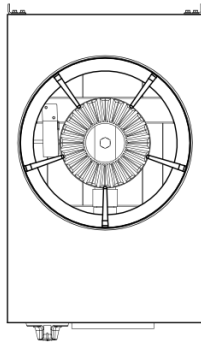
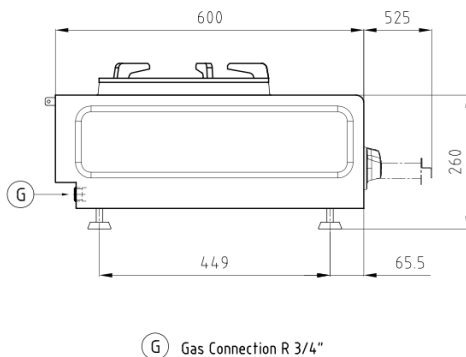
FRONT**TOP****SIDE**

*Overall dimension in mm

TECHNICAL DATA**External Dimensions**

Width	: 400 mm
Depth	: 600 mm
Height	: 300 mm

Cooking Surface

Cooking zones	: Ø 330 mm
---------------	------------

Gas Power Rating

Heat input total	: LPG 11.5 kW, Natural Gas 13 kW
No. of burners	: 1
Control type	: Open and close system.
Gas type options	: LPG G30, G31 Natural Gas G20, G25

Connections

Gas	: DN 20 (3/4")
Water	: N/A
Drain	: N/A

Heat & Steam Emissions

Direct heat emission	: 3.25 kW
Latent heat emission	: 1.3 kW
Steam emission	: 1.9 kg/h

PACKAGING DATA

Width	: 430 mm
Depth	: 630 mm
Height	: 420 mm
Volume	: 0.11 m ³

WEIGHT

Net Weight	: 26 kg
Gross Weight	: 29 kg