

## Oriental Cooking - Wok Range

### Gas - Wok Kwalie / CE

#### NGK S 40-90 W1



Due to continuous technical development, the image shown may not represent the latest design of the unit.

#### DESCRIPTION

Single burner gas wok with a high-performance jet-burner and a power rate of 33 kW. Compact, powerful and suitable for various methods of Oriental cooking, the NGK wok is the perfect choice for any kitchen.

Made of stainless steel AISI 304 with a slanted, deep drawn 3.2 mm strong, reinforced top panel with a heavy-duty removable cast iron wok ring. Cold-water supply with one swivel faucet, mounted on the backsplash, easily operable from the front panel.

The intelligent deck cooling & cleaning system with spray nozzles guarantee an efficient cooling of the top panel and an enhanced hygienic as food debris are flushed away towards the drain channel in the back. The built-in strainer avoids congestions of the drain.

#### OTHER AVAILABLE MODELS

- NGK S 40-75 W1
- NGK S 80-75 W2
- NGK S 120-75 W3
- NGK S 40-90 W1S1
- NGK S 80-90 W2S1
- NGK S 80-90 W2S2

#### MAIN FEATURES

- One atmospheric jet-burner with a power rate of 33 kW.
- Manual ignition.
- Equipped with pilot burner, safety thermocouple, gas valve, gas knee lever.
- Slanted, reinforced (3.2 mm) top panel with drain channel and removable strainer in the back for easy operation.
- Cold-water supply with one swivel faucet mounted on the backsplash.
- Deck cooling & cleaning system with spray nozzles for maximum hygiene.
- Suitable for wok-pan sizes Ø 14-18" (355-457 mm).
- CE certified unit.

#### CONSTRUCTION

- Sturdy frame made of stainless steel AISI 430.
- Slanted, reinforced stainless steel top panel (3.2 mm), AISI 304 with hairline surface pattern.
- Front and side panels made of stainless steel AISI 304 with hairline surface pattern (0.8 mm).
- Backsplash made of stainless steel AISI 304 with hairline surface pattern (1.2 mm).
- Tubular, height adjustable ( $\pm 25$  mm) stainless steel legs.
- Type of installation: free standing.
- Frame, top and panels, all made of high-grade stainless steel.

#### INCLUDED ACCESSORIES

- Wok stand (1 pc)

#### OPTIONAL ACCESSORIES

- Burner nozzle kit - converts the wok burner power rate from 33 kW to 24 kW.
- Condiment tray made of stainless steel AISI 304 (300x300 mm).

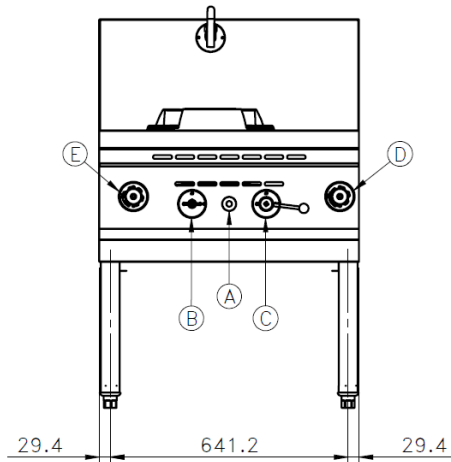
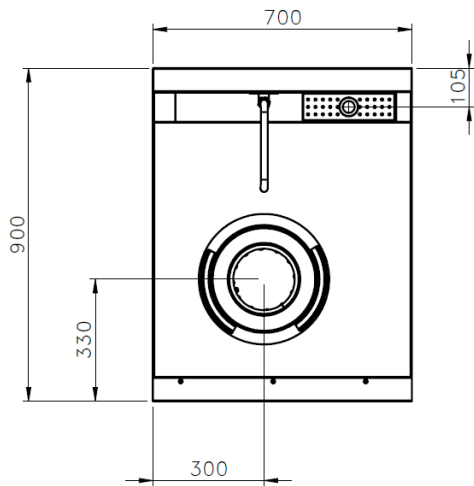
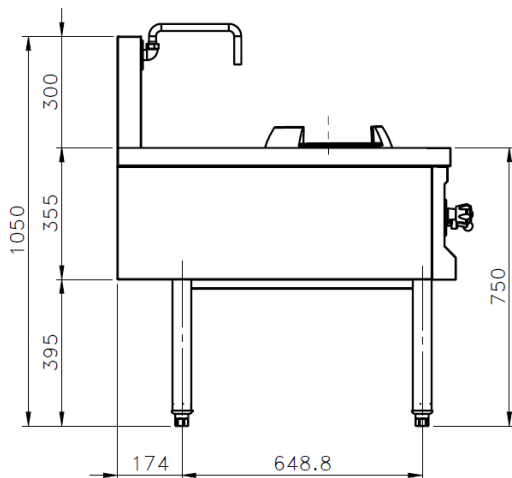
**FRONT****TOP****SIDE**

\*Overall dimension in mm

**TECHNICAL DATA****External Dimensions**

Width	: 700 mm
Depth	: 900 mm
Height	: 750/1050 mm

**Cooking Surface**

Wok burners	: Ø 280 mm
Soup burners	: N/A

**Gas Power Rating**

Heat input total	: LPG/LNG 33 kW
No. of burners	: 1
Control type	: Open-close valve
Gas type options:	LPG G30, G31 LNG G20, G25

**Connections**

Gas	: DN 20 (3/4")
Water	: DN15 (1/2")
Drain	: DN25 (1")

**Heat & Steam Emissions**

Direct heat emission	: LPG/LNG 8.25 kW
Latent heat emission	: LPG/LNG 4.95 kW
Steam emission	: LPG/LNG 8.75 kg/h

**PACKAGING DATA**

Width	: 780 mm
Depth	: 930 mm
Height	: 1170 mm
Volume	: 0.85 m <sup>3</sup>

**WEIGHT**

Net Weight	: 64 kg
Gross Weight	: 82 kg