

Asian Cooking - Wok Range
Gas - Wok Kwalie High Pressure
NGKH 12-75



Due to continuous technical development, the image shown may not represent the latest design of the unit.

DESCRIPTION

Gas wok with two powerful, high-pressure burners, each with a power rate of 35 kW. Compact, efficient and suitable for various methods of Asian cooking, the NGKH high-pressure wok is the perfect choice for any kitchen.

Made of stainless steel AISI 304 with a deep drawn 1.2 mm strong, reinforced (1 mm) top panel and heavy-duty removable cast iron wok rings. Cold-water supply with one swivel faucet mounted on the backsplash, easily operable from the front panel.

The intelligent deck cooling & cleaning system with spray nozzles guarantee efficient cooling of the top panel and enhanced hygiene as food debris is flushed away towards the drain channel in the back. The built-in strainer avoids the congestion of the drain.

OTHER AVAILABLE MODELS

- NGKH 6-75

MAIN FEATURES

- Two atmospheric, high-pressure burners with a power rate of 35 kW each.
- Manual ignition.
- Equipped with pilot burners, safety thermocouples, gas valves, gas knee levers.
- Slanted, deep drawn stainless steel top panel AISI 304 (1.2 mm) with stainless steel reinforcement (1 mm) and a drain channel with a removable strainer in the front.
- Cold-water supply with one swivel faucet mounted on the backsplash.
- Deck cooling & cleaning system with spray nozzles for maximum hygiene.
- Suitable for wok-pan sizes Ø 14-18" (355-457 mm).

CONSTRUCTION

- Sturdy frame made of stainless steel AISI 430.
- Slanted, deep drawn stainless steel top panel AISI 304 (1.2 mm) with stainless steel reinforcement (1 mm) and hairline surface pattern.
- Front and side panels made of stainless steel AISI 430 with hairline surface pattern (0.8 mm).
- Backsplash made of stainless steel AISI 304 with hairline surface pattern (1.2 mm).
- Tubular, height adjustable (± 10 mm) stainless steel legs.
- Type of installation: free standing.
- Frame, top and panels, all made of high-grade stainless steel.

INCLUDED ACCESSORIES

- Wok stand (2 pcs)

OPTIONAL ACCESSORIES

- Ladle / basket holder
- Condiment tray made of stainless steel AISI 304 (300x300 mm).

PT. NAYATI INDONESIA

www.nayati.com

Nayati reserves the right to make product alterations and or price adjustments at any time and can not be held responsible for any printing errors or omissions.

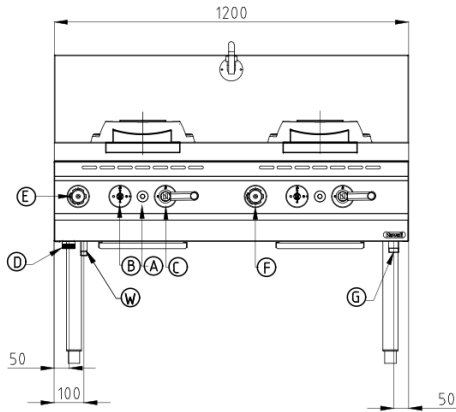
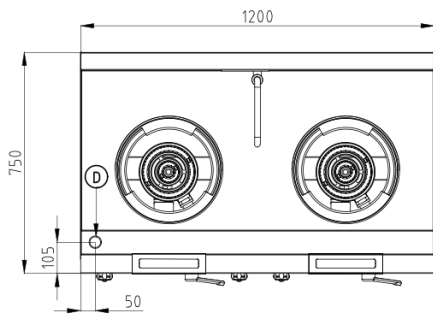
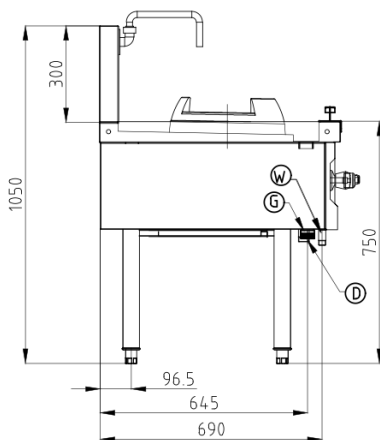
FRONT**TOP****SIDE**

*Overall dimension in mm

TECHNICAL DATA**External Dimensions**

Width	: 1200 mm
Depth	: 750 mm
Height	: 750/1050 mm

Cooking Surface

Wok burners	: 2 x Ø 280 mm
Soup burners	: N/A

Gas Power Rating

Heat input total	: LPG 70 kW
No. of burners	: 2
Control type	: Open-close valve
Gas type options:	LPG 0.5...1.0 bar
	Natural Gas N/A

Connections

Gas	: DN25 (1")
Water	: DN15 (1/2")
Drain	: DN32 (1 1/4")

Heat & Steam Emissions

Direct heat emission	: LPG 17.5 kW
Latent heat emission	: LPG 10.50 kW
Steam emission	: LPG 18.56 kg/h

PACKAGING DATA

Width	: 1300 mm
Depth	: 870 mm
Height	: 1250 mm
Volume	: 1.41 m ³

WEIGHT

Net Weight	: 101 kg
Gross Weight	: 131 kg