

Oriental Cooking - Wok Range Chinese Pro Gas - Wok Kwalie with Blower / CE NGKB 16-90 W2N1 CLN



Due to continuous technical development, the image shown may not represent the latest design of the unit.

DESCRIPTION

Guang Dong style, high-performance wok with blower. Equipped with two 40 kW premix burners, each built in a fire brick chamber for highest thermal efficiency with a low combustion noise of below 70 dBA. The neutral water/soup pan in the rear has a capacity of nine liters and is warmed up by the residual heat from the premix wok burner. This wok is designed to meet the needs of professional Chinese chefs and is the perfect solution for high-frequent Asian restaurants.

Slanted, 3.2 mm strong, reinforced top panel made of stainless steel AISI 304 with heavy-duty removable cast iron wok ring. Coldwater supply with one swivel faucet mounted on the back-splash, easily operable from the front panel.

The intelligent deck cooling & cleaning system with spray nozzles guarantee an efficient cooling of the top panel and an enhanced hygienic as food debris are flushed away towards the drain channel in the front. The built-in strainer avoids congestions of the drain.

OTHER AVAILABLE MODELS

- NGKB 8-90 W1 CLN
- NGKB 15-90 W2 CLN
- NGKB 11-90 W1N1 CLN
- NGKB 11-90 W1N1 LBS CLN
- NGKB 22-90 W2N2 CLN
- NGKB 22-90 W2N2 LBS CLN
- NGKB 12-125 W1N1 CLN
- NGKB 22-125 W2N2 CLN

MAIN FEATURES

- Two powerful 40 kW premix wok burners built in fire brick chambers for high thermal efficiency with low combustion noise (<70 dB).
- Concealed blower design.
- Electric ignition.
- Equipped with pilot burners, safety thermocouples, gas valves, gas knee levers.
- Slanted top panel with domes for wok burners and water/soup pan.
- Cold-water supply with one swivel faucet mounted on the backsplash.
- Deck cooling & cleaning system with spray nozzles for maximum hygiene and easy operation.
- Stainless steel, 9 liters water/soup pan (1pc).
- Suitable for wok-pan sizes Ø 18-24" (457-610 mm).
- CE certified unit.

CONSTRUCTION

- Sturdy frame made of stainless steel AISI 430.
- Slanted, reinforced stainless steel top panel (3.2 mm), AISI 304 with hairline surface pattern.
- Front and side panels made of stainless steel AISI 430 with hairline surface pattern (0.8 mm).
- Backsplash made of stainless steel AISI 304 with hairline surface pattern (1.2 mm).
- Tubular, height adjustable (± 25 mm) stainless steel legs.
- Types of installations: free standing or placed on a plinth.
- Frame, top and panels, all made of high-grade stainless steel.

INCLUDED ACCESSORIES

- Wok stand (2 pcs)
- Ladle / basket holder (2 pcs)
- Stainless steel water/soup pan (1pc)

OPTIONAL ACCESSORIES

- N/A

PT. NAYATI INDONESIA

www.nayati.com

Nayati reserves the right to make product alterations and or price adjustments at any time and can not be held responsible for any printing errors or omissions.

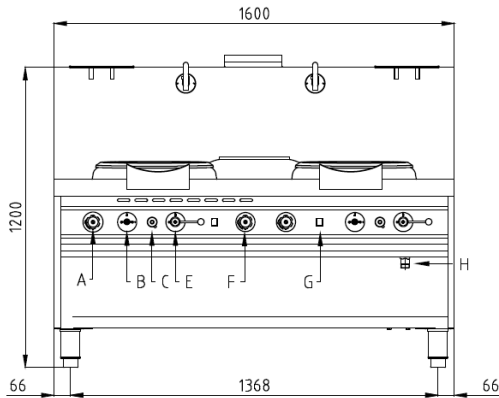
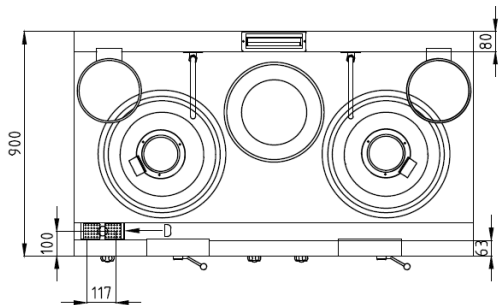
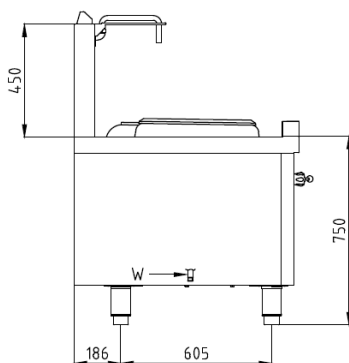
FRONT**TOP****SIDE**

*Overall dimension in mm

TECHNICAL DATA**External Dimensions**

Width	: 1600 mm
Depth	: 900 mm
Height	: 750/1200 mm

Cooking Surface

Wok burners	: 2 x Ø 330 mm
Soup burners	: N/A

Gas Power Rating

Heat input total	: LPG/LNG 80 kW
No. of burners	: 2
Control type	: Open-close valve
Gas type options:	LPG G30, G31 LNG G20, G25

Electrical Supply Data

Total connected load	: 0.38 kW
Voltage	: 230V, 1NPE AC / 50-60 Hz
Recommended fuse	: 6 A (slow)

Connections

Gas	: DN25 (1")
Water	: DN15 (1/2")
Drain	: DN40 (1 1/2")

Heat & Steam Emissions

Direct heat emission	: LPG/LNG 20.00 kW
Latent heat emission	: LPG/LNG 12.00 kW
Steam emission	: LPG 21.20 kg/h

PACKAGING DATA

Width	: 1630 mm
Depth	: 930 mm
Height	: 1320 mm
Volume	: 2.00 m ³

WEIGHT

Net Weight	: 410 kg
Gross Weight	: 467 kg