

Modular Cooking - Meritus

Neutral Counter

NNWC 8-75 (ME)



Due to continuous technical development, the image shown may not represent the latest design of the unit.

DESCRIPTION

Modular neutral working counter with 750 mm depth, 6000 square-centimeter working area.

Usable for preparation phase before/after cooking processes and storage of crockery and tools.

Made of AISI 304 with 1.5 mm top thickness.

OTHER AVAILABLE MODELS

- NNWC 4-75 (ME)
- NNWC 6-75 (ME)
- NNWC 4-75 1D (ME)
- NNWC 6-75 1D (ME)
- NNWC 8-75 2D (ME)
- NNWC 4-75 SD (ME)
- NNWC 6-75 SD (ME)
- NNWC 8-75 SD (ME)
- NNWC 4-75 1D/SD (ME)
- NNWC 6-75 1D/SD (ME)
- NNWC 8-75 2D/SD (ME)

MAIN FEATURES

- Neutral working counter with 800 x 750 mm surface.
- Open cabinet without door.

CONSTRUCTION

- External construction entirely with AISI 304.
- Top panel with 1.5 mm thickness. Orbital surface finishing: resistant toward scratches.
- Front panel is constructed of 0.8 mm AISI 304 with satin surface finish.
- Side panel is constructed of 0.8 mm AISI 304 with satin surface finish.
- Adjustable +/- 25 mm AISI leg.
- Nayati connection system between Meritus products on the front panels, cabinets, and splashbacks.
- Cabinet executed with H2 radius.
- Deep drawn front panel to minimize liquid penetration to the internal part.
- Gasket protection behind the knobs to prevent water to seeping in, prolonging main heating regulation parts.
- IPX5 water protection level.

INCLUDED ACCESSORIES

- N/A

OPTIONAL ACCESSORIES

- Joint clip ME.

FRONT

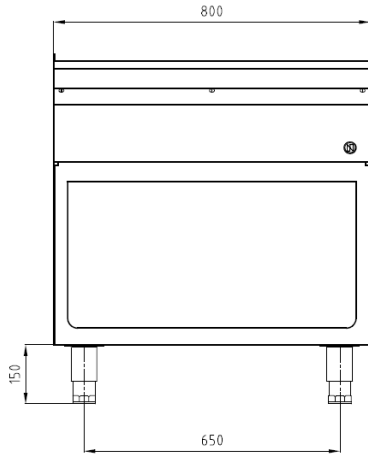

TOP

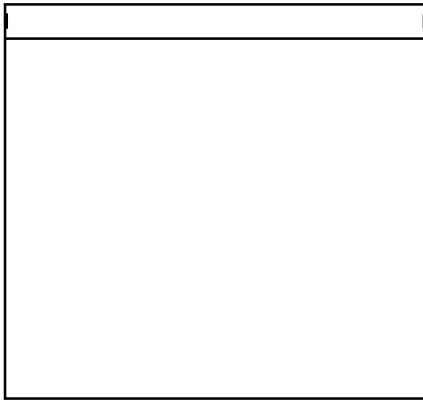

SIDE

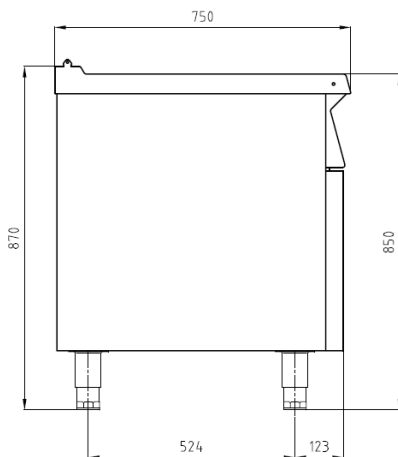

*Overall dimension in mm

TECHNICAL DATA

External Dimensions

Width : 800 mm
Depth : 750 mm
Height : 850/870 mm

PACKAGING DATA

Width : 830 mm
Depth : 780 mm
Height : 990 mm
Volume : 0.64 m³

WEIGHT

Net Weight : 58 kg
Gross Weight : 79 kg

PT. NAYATI INDONESIA

www.nayati.com

Nayati reserves the right to make product alterations and or price adjustments at any time and can not be held responsible for any printing errors or omissions.

11/09/2020