

## Modular Cooking - Grandis

### Neutral Counter

#### NNWC 8-90 GR



Due to continuous technical development, the image shown may not represent the latest design of the unit.

#### DESCRIPTION

Modular neutral working counter with 900 mm depth, 7200 square-centimeter working area.

Usable for preparation phase before/after cooking processes and storage of crockery and tools.

Made of AISI 304 with 2 mm top thickness.

#### OTHER AVAILABLE MODELS

- NNWC 4-90 GR
- NNWC 6-90 GR
- NNWC 4-90 GR DR
- NNWC 6-90 GR DR
- NNWC 8-90 GR DR
- NNWC 4-90 GR D
- NNWC 6-90 GR D
- NNWC 8-90 GR D
- NNWC 4-90 GR D DR
- NNWC 6-90 GR D DR
- NNWC 8-90 GR D DR

#### MAIN FEATURES

- Neutral working counter with 800 x 900 mm surface.
- Open cabinet without door.

#### CONSTRUCTION

- External construction entirely with AISI 304.
- Top panel with 2 mm thickness. Orbital surface finishing: resistant toward scratches.
- Front panel is constructed of 1 mm AISI 304 with satin surface finish.
- Side panel is constructed of 0.8 mm AISI 304 with satin surface finish.
- Adjustable +/- 25 mm AISI leg.
- Cabinet executed with H2 radius.
- Connector between Grandis product on the front and the back.
- IPX4 water protection level.

#### INCLUDED ACCESSORIES

- N/A

#### OPTIONAL ACCESSORIES

- Joint clip GR.

**FRONT**

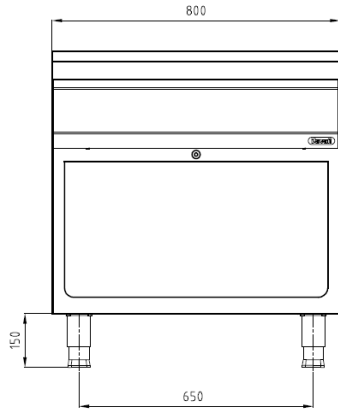

**TOP**

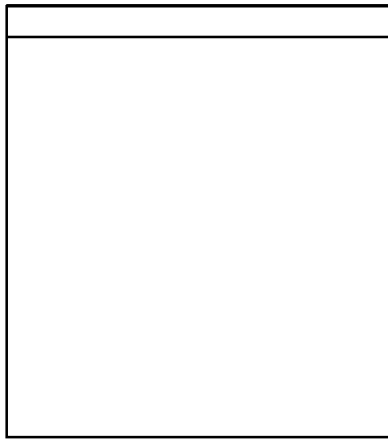

**SIDE**

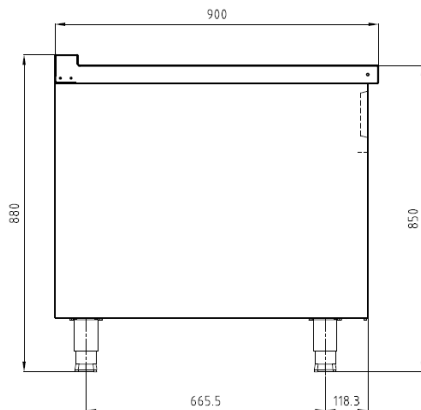

\*Overall dimension in mm

**TECHNICAL DATA**

**External Dimensions**

Width : 800 mm  
Depth : 900 mm  
Height : 850/880 mm

**PACKAGING DATA**

Width : 830 mm  
Depth : 930 mm  
Height : 1000 mm  
Volume : 0.77 m<sup>3</sup>

**WEIGHT**

Net Weight : 58 kg  
Gross Weight : 80 kg