

## Smart Oven - Pizza Oven

Gas - Pizza Oven

NPSO 110.74

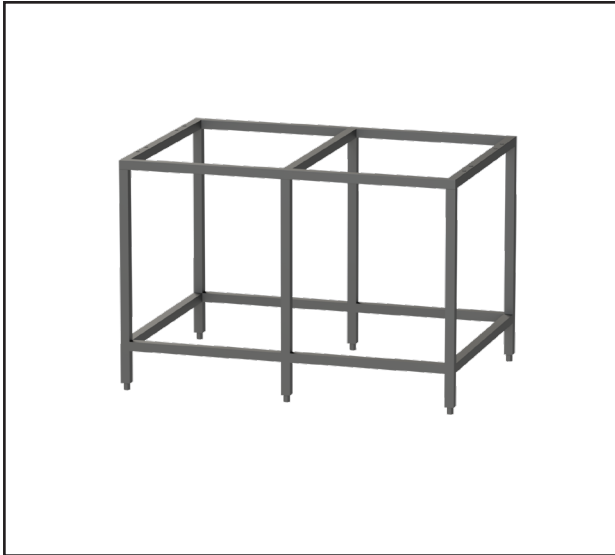

Due to continuous technical development, the image shown may not represent the latest design of the unit.

### DESCRIPTION

Stand for NEPO 80.70-S.

Made entirely of stainless steel 304 with square tubes and fully welded to minimize dirt accumulation.

### OTHER AVAILABLE MODELS

- N/A

### MAIN FEATURES

- Stand for NEPO 80.70-S.

### CONSTRUCTION

- Constructed from square tube stainless steel 304.
- Reinforced with horizontal square tube between legs.
- Constructed with six legs for stability.

### INCLUDED ACCESSORIES

- N/A.

### OPTIONAL ACCESSORIES

- N/A

**FRONT**

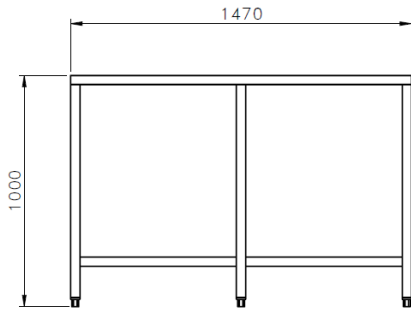

**TOP**

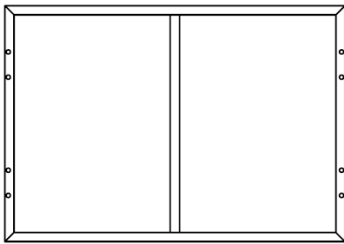

**SIDE**

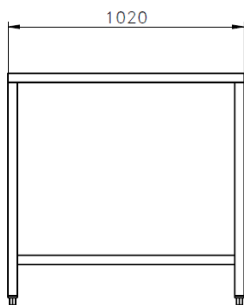

**TECHNICAL DATA**

External Dimensions

Width : 1470 mm  
 Depth : 1020 mm  
 Height : 1000 mm

PACKAGING DATA

Width : 1500 mm  
 Depth : 1050 mm  
 Height : 1120 mm  
 Volume : 1.76 m<sup>3</sup>

WEIGHT

Net Weight : 46 kg  
 Gross Weight : 56.9 kg

\*Overall dimension in mm

PT. NAYATI INDONESIA

[www.nayati.com](http://www.nayati.com)

Nayati reserves the right to make product alterations and or price adjustments at any time and can not be held responsible for any printing errors or omissions.

09/05/2020