

Asian Cooking - Roaster & Grill

Gas - Duck Roaster

NGDR 900 H



Due to continuous technical development, the image shown may not represent the latest design of the unit.

DESCRIPTION

Gas duck roaster, equipped with a powerful, atmospheric high-pressure burner of 35 kW power rate and a roasting capacity for twelve ducks.

Made of stainless steel and designed for ease of use with a lift top-lid to access the duck hanging-rail. Equipped with an observation door, ventilation cover, temperature gauge and a drainage area to collect the dropping oil.

OTHER AVAILABLE MODELS

- NGDR 900
- NGDR 900 CE (double layer)

MAIN FEATURES

- Powerful atmospheric high-pressure burner with a power rate of 35 kW.
- Ventilation opening with cover in the top lid.
- Piezo ignition.
- Equipped with pilot burner, safety thermocouple, gas valve, gas knob.
- Stainless steel rail for twelve ducks.
- Oil/grease collection area with drainage.
- Temperature gauge.

CONSTRUCTION

- Unit made of stainless steel AISI 304.
- Dome (three parts) and lid made of stainless steel AISI 304 (1.0 mm).
- Legs made of stainless steel AISI 304 (6 mm).
- Types of installations: free standing.
- Unit made of high-grade stainless steel.

INCLUDED ACCESSORIES

- Duck hanging rails.

OPTIONAL ACCESSORIES

- Stainless steel 9" roast duck hook.
- S-hook 15" with wooden handle .

FRONT

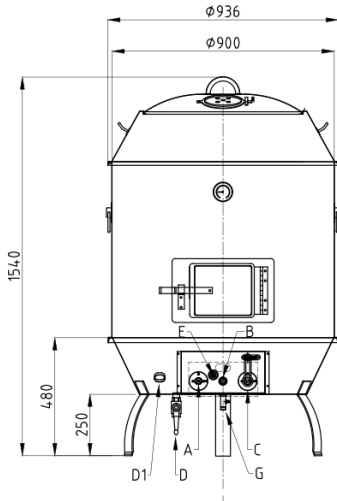

TOP

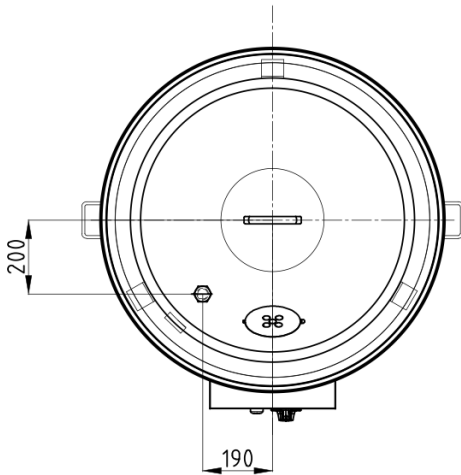

SIDE

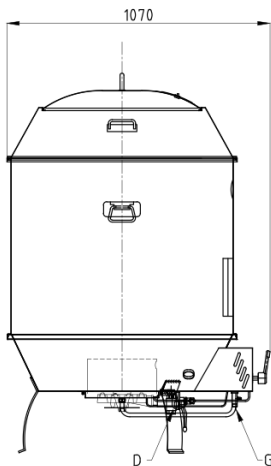

*Overall dimension in mm

TECHNICAL DATA

External Dimensions

Width : Ø 936 mm
Depth : 1070 mm
Height : 1607 mm

Cooking Surface

Cooking zones : 12 ducks, Ø 900 mm

Gas Power Rating

Heat input total : LPG 35 kW
No. of burners : 1
Control type : High-low power control
Gas type options : LPG G30, G31
Natural Gas N/A

Connections

Gas : DN15 (1/2")
Water : N/A
Drain : DN20 (3/4")

Heat & Steam Emissions

Direct heat emission : LPG 12.25 kW
Latent heat emission : LPG 7.00 kW
Steam emission : LPG 10.29 kg/h

PACKAGING DATA

Width : 940 mm
Depth : 940 mm
Height : 1670 mm
Volume : 1.48 m³

WEIGHT

Net Weight : 52 kg
Gross Weight : 81 kg