

## Furnitures - Stainless Steel Furnitures

### Food Distribution Trolley

#### NFDT 9-70 NH



Due to continuous technical development, the image shown may not represent the latest design of the unit.

#### DESCRIPTION

Food Distribution Trolley with 18 trays and mobile castors. Completed with handles for mobility.

Perfect for banquet, canteen, institution and hospital food services.

Designed with insulated chamber to minimize heat losses, four corner bumpers for protection, secure door locking system, and fall-protection stopper.

#### OTHER AVAILABLE MODELS

- NFDT 9-70 NH (B)
- NFDT 9-70 H (A)
- NFDT 9-70 H (B)

#### MAIN FEATURES

- Food Distribution Trolley.
- Capacity of 18 trays that fit 18 x GN 1/1 Food Pan.
- Equivalently hold the capacity of 36 plates with diameter of 31 cm.
- Distance between shelf is 70 mm.
- Equipped with two vertically-positioned and heat-insulated handles for mobility and comfort.
- Equipped with four durable corner bumpers.
- Upper part of the trolley equipped with fall-protection stopper for additional quick storage.
- Chamber dimension of 734 x 640 x 674 mm.

#### CONSTRUCTION

- Interior and exterior panel made entirely of stainless steel AISI 304.
- Equipped with 5" heavy duty casters.
- Two rigid caster and two swiveling casters with brake.
- Double-walled doors to keep minimize temperature losses.

#### SUPPLIED INCLUDING :

- Standard Accessories
- Transport to location and Installation
- Include foodpan GN 1/1 18 pcs

PT. NAYATI INDONESIA

[www.nayati.com](http://www.nayati.com)

Nayati reserves the right to make product alterations and or price adjustments at any time and can not be held responsible for any printing errors or omissions.

**FRONT**

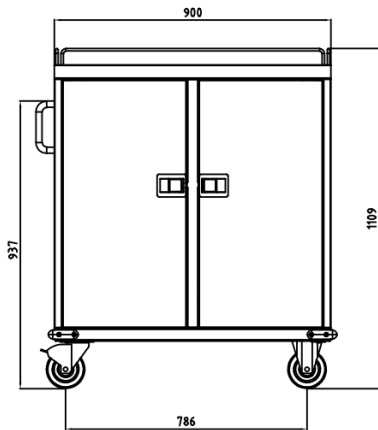

**TECHNICAL DATA**

**External Dimensions**

Width : 900 mm  
 Depth : 700 mm  
 Height : 1109 mm

**PACKAGING DATA**

Width : 1040 mm  
 Depth : 800 mm  
 Height : 1310 mm  
 Volume : 1.09 m<sup>3</sup>

**WEIGHT**

Net Weight : 90 kg  
 Gross Weight : 100 kg

**TOP**

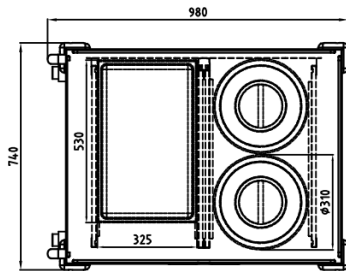

**SIDE**

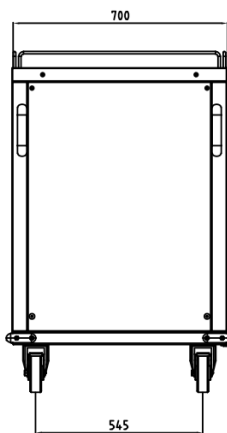

\*Overall dimension in mm

PT. NAYATI INDONESIA

[www.nayati.com](http://www.nayati.com)

Nayati reserves the right to make product alterations and or price adjustments at any time and can not be held responsible for any printing errors or omissions.

25/11/2021